

woodio®

**BLOCK
INSTALLATION INSTRUCTIONS**

MADE IN FINLAND

Woodio products are manufactured in Finland at Woodio's own factory in Helsinki. The Association for Finnish Work has awarded all Woodio products the Key Flag symbol in recognition of products made in Finland. We have also been awarded the Design from Finland mark that is awarded to companies that have contributed to Finnish design. We are proud to carry these awards as a symbol of Finnish work, design and craftsmanship.



**DESIGN DEED
OF THE YEAR
2019**



WOODIO BLOCK INSTALLATION



1.

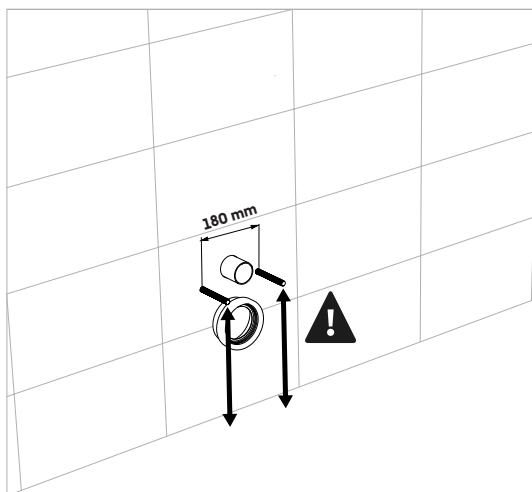

! Please note, that the installation requires a pre-installed concealed cistern that must comply with standard EN 14055:2010. Leave enough space between the floor to tighten the bolts.

2.

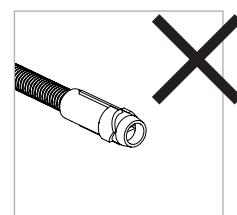
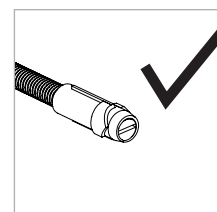
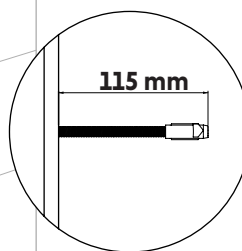
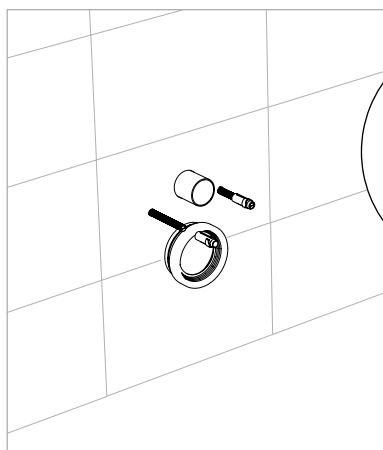

3.

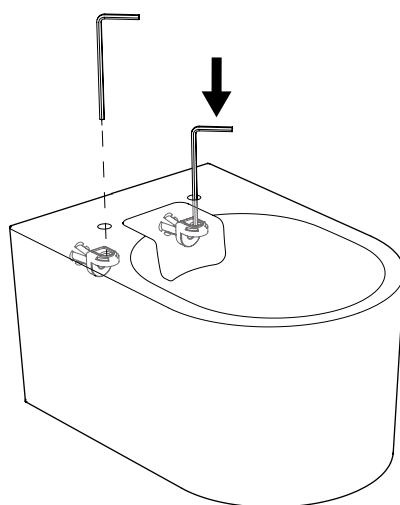



4.

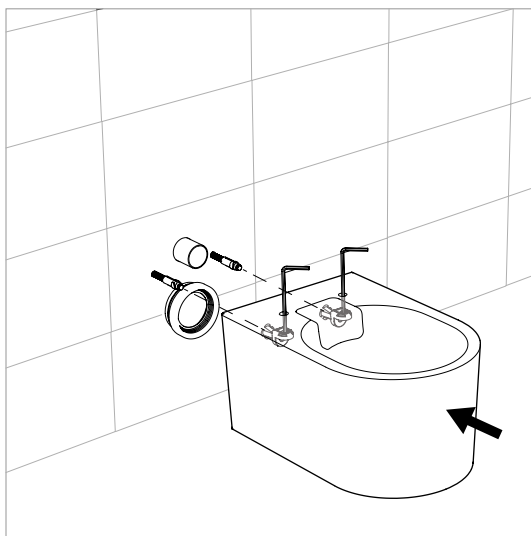

5.

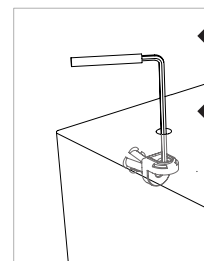
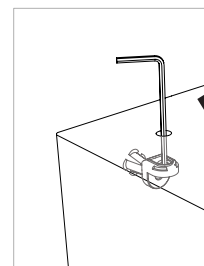
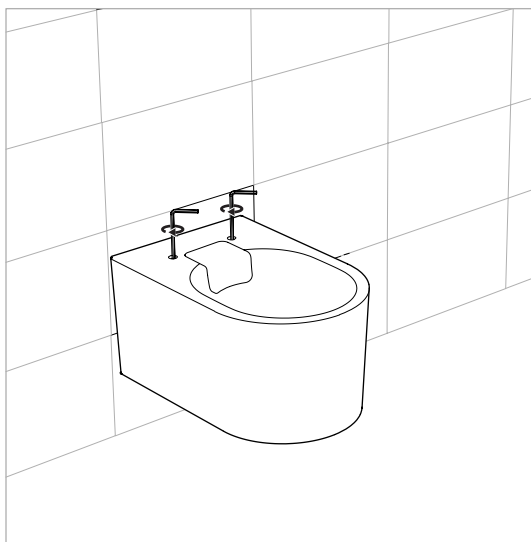

6.

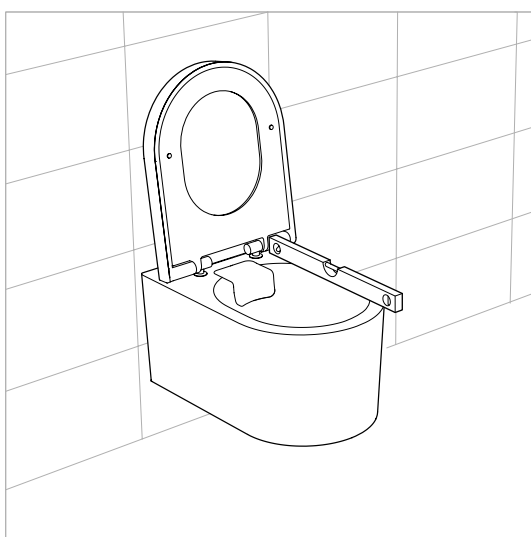



7.

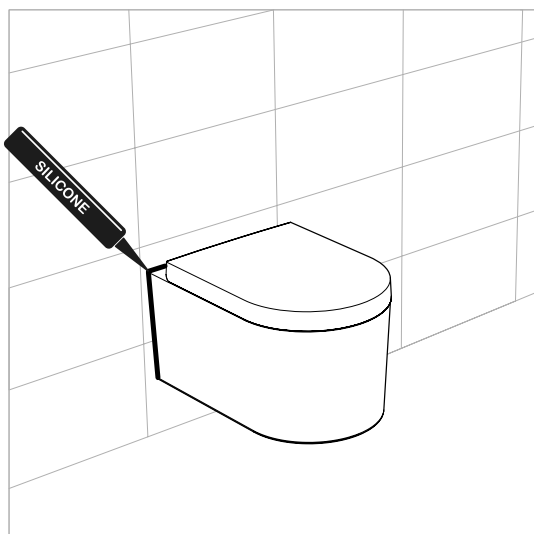

8.

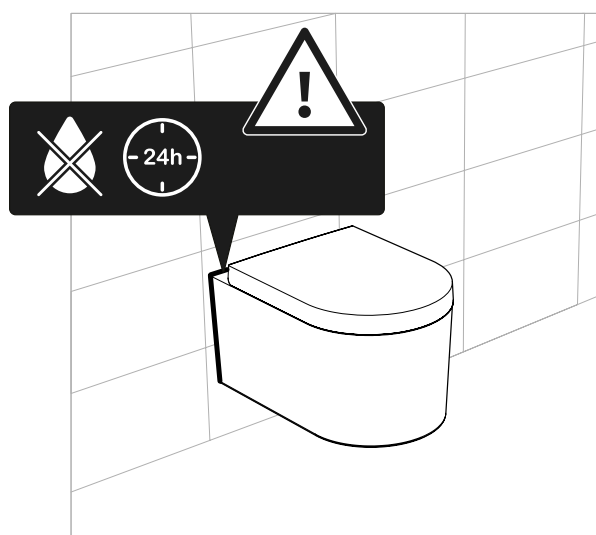



STANDARDS COMPLIANT

Complies with EU sanitary appliances standard (EN997:2012).

Can be disposed as energy waste.



CARE INSTRUCTIONS

Clean with a water dampened soft cloth and a mild non-abrasive dish detergent or soap. Do not use steel wool, hard or sharp tools which can scratch the surface.



CUSTOMER CARE

woodio@woodio.fi

+358 50 478 2944

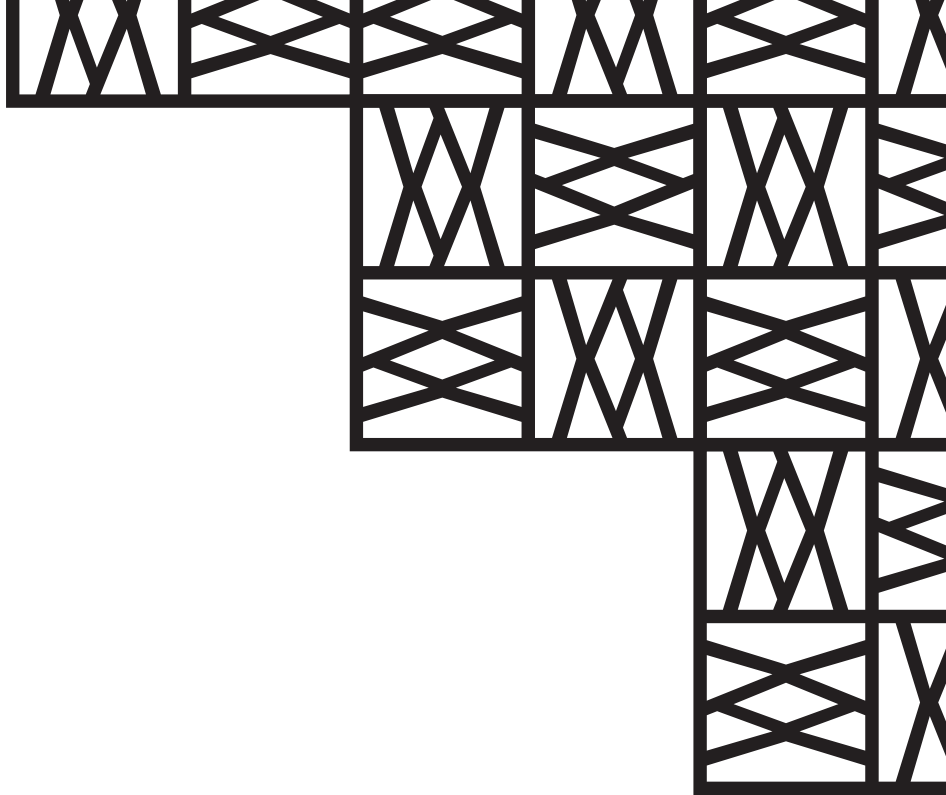

Yes, it's wood.

WOODIO OY, FINLAND

WWW.WOODIO.FI